



GraviTflo Dosing System

Our Unique Dispensing System

BENEFITS

- No chemical contact dispensing giving increased safety
- No water source needed to install or operate the system
- Low equipment costs
- Simple system that is easy to use
- Will fit any bottle size and can be installed into the smallest of places

KEY FEATURES

- Size: 38mm
- Dosing sizes: 1/4 oz | 1/2 oz | 1 oz | 2 oz | 7mm | 15mm | 30mm | 45mm | 60mm
- Works with Round or F style bottles
- Hanging kits includes: Wall rail | clamps | screws
- Sustainably manufactured

**PATENT: 8,220,665 |
10,889,486**

The OneFlo | GraviTflo is a unique dispensing system featuring our Closed-Loop technology in an inverted application. GraviTflo is the only solution of its kind and is ideal for areas without a water source or where water pressure is a concern.

Once the chemical bottle is placed on the dispenser, the insert valve opens to release chemicals into the reservoir of the dispenser. When the end-user is ready to dispense the concentrate for dilution, they simply press up on the dosing mechanism, and a metered amount of chemical concentrate empties into the receiving bottle, mop bucket or other type of container.

This system offers guaranteed accuracy for each and every dose. Accurate dilution ensures maximum product performance and cost effective use. The Closed-Loop system ensures enhanced safety when transporting concentrated chemical bottles, mop buckets and compatible to an open feed system.

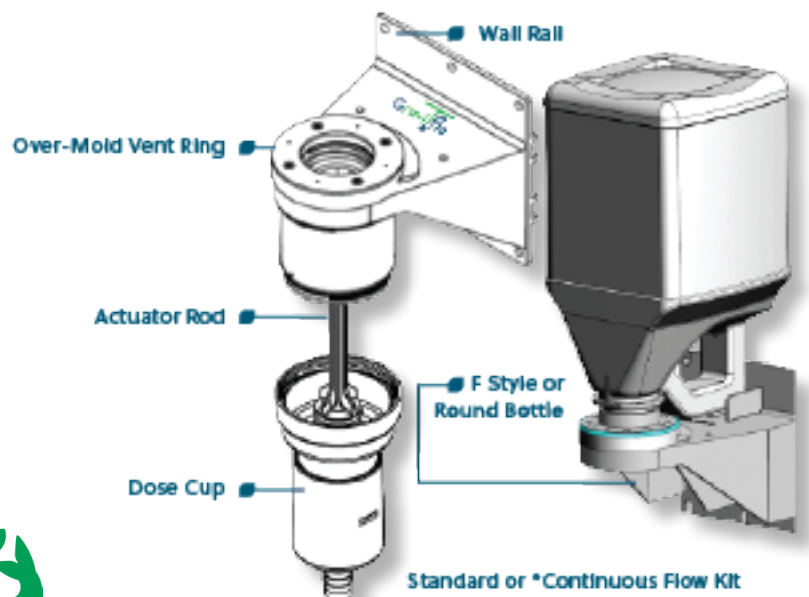

Made In USA



rdindustries.com
sales@rdindustries.com
P: 1.800.759.7090

