



Wall Dispenser

The Number One Low-Cost Maintenance Free Chemical Dispensing Solution

BENEFITS

- Compatible with SafTflo Inserts | SafTflo Cap
- Adapters | SafTflo Fluid Monitor
- Low cost to fix
- Quick and easy to install
- Accurate dilution and superior flow rates
- Less need for external service repair engineers
- Increased safety for your team
- Made in Omaha, Nebraska USA

KEY FEATURES

- One or two port modules
- No chemical contact with working parts
- Patented SafTgap™ Backflow Prevention, one way check valve and air-gap educators
- ASSE 1055 Certified
- Customizable
- Space saving

PATENT: 9,296,000

The SafTflo Wall Dispenser offers a simple chemical dispensing system. It reduces costly maintenance calls as the simple system provides for easy user repair.

Offering the flexibility of a one or two part module, a choice of flow rates and interchangeable Kynar metering



tips, it delivers accurate dilution for use in many applications. RD Industries SafTgap™ is patented technology offering air-gap and a one-way check valve for increased performance and safety.

Simple to install and operate, this compact unit can fit into small spaces or scaled up by connecting multiple dispensers.

Customizable to suit your needs and designed to ensure chemical concentrates do not come into contact with the working parts. The lifetime of this unit is increased compared to others on the market.

As a part of RD Industries Closed-Loop family, the SafTflow Wall Dispenser provides superior safety for your team and will help meet your sustainability goals.

Made In USA



rdindustries.com

sales@rdindustries.com

P: 1.800.759.7090

F: 402.455.8242

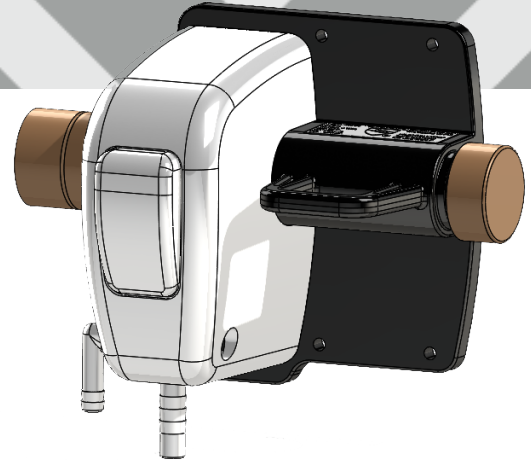

Accessories

Included in the Kit	Add on Items
Metering Tips	Single Bottle Holder
Hose Hanger	Dual Bottle Holder
Chemical Tube	Brass Plastic Quick Connect
Discharge Tube	Water Hose
Swivel Connector	
End Cap	

Instructions available in English, Spanish, Portuguese, French and German.

*Depends on availability of brass during covid delays

Industries The Use These Products



Janitorial



Sanitation



Laundry



Warewash



Animal Health

Flow Rate

Flow Rate	1 GPM (4L/M)	2GPM (8L/M)	3.5PM (14L/M)
Single Dilution	Yes	Yes	Yes
Dual Dilution	Yes	Yes	Yes

Dual dilution can be any combination of flow rates

Wall Dispenser

	Body	Buttons
White Only	Yes	Yes
Branded Logo	Yes	No

Dual dilution can be any combination of flow rates